

Title SAM4S8B MAIN: Microprocessor		
Size A4	Document Number TV-GENERATOR-SAM4-1-3-CXA1645.DSN	Rev 1.3
Date: Tuesday, March 13, 2018	Sheet 1	of 5

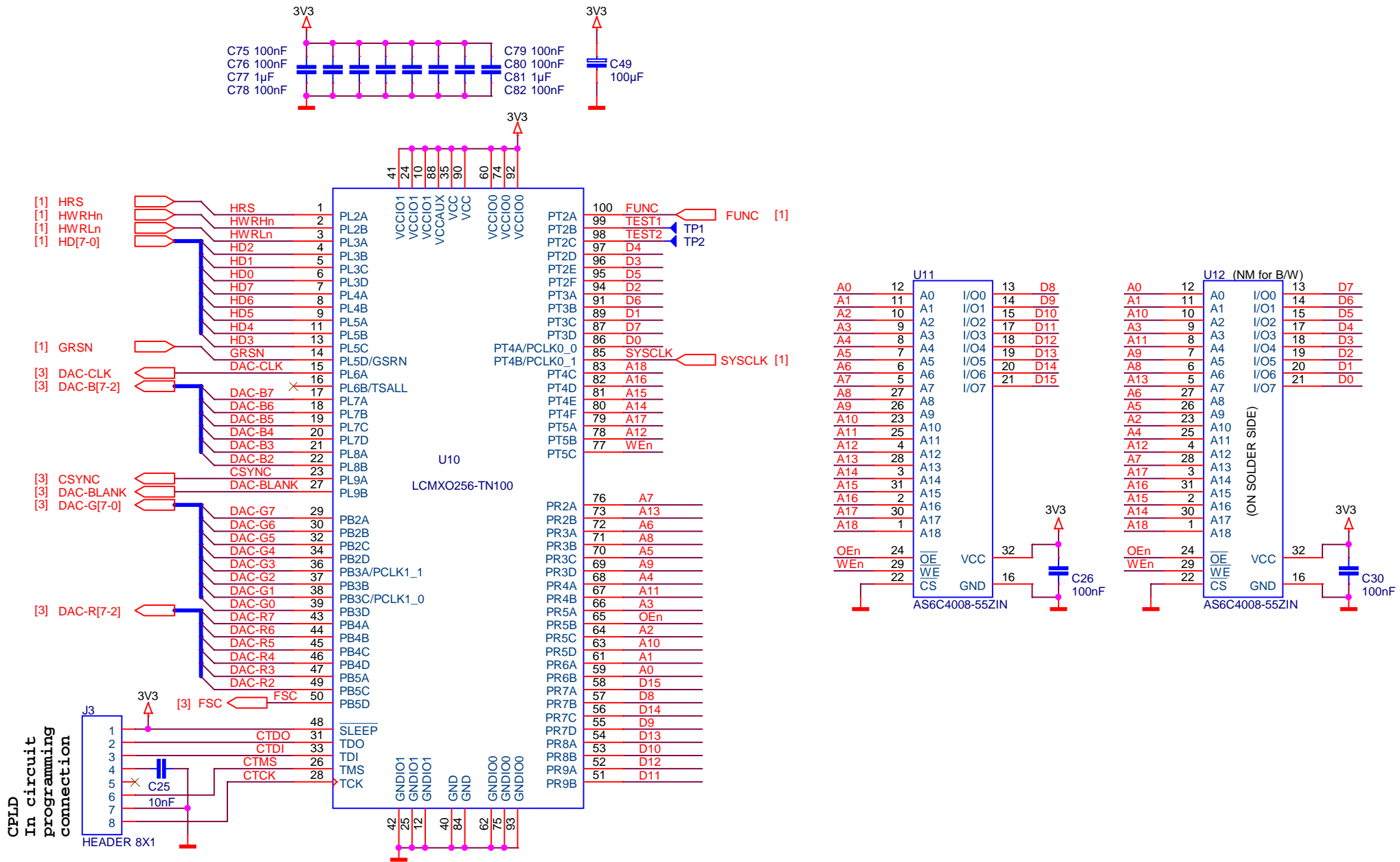

Title		
SAM4S8B MAIN: CPLD + Frame Buffer		
Size	Document Number	Rev
A4	TV-GENERATOR-SAM4-1-3-CXA1645.DSN	1.3
Date:	Friday, February 23, 2018	Sheet 2 of 5

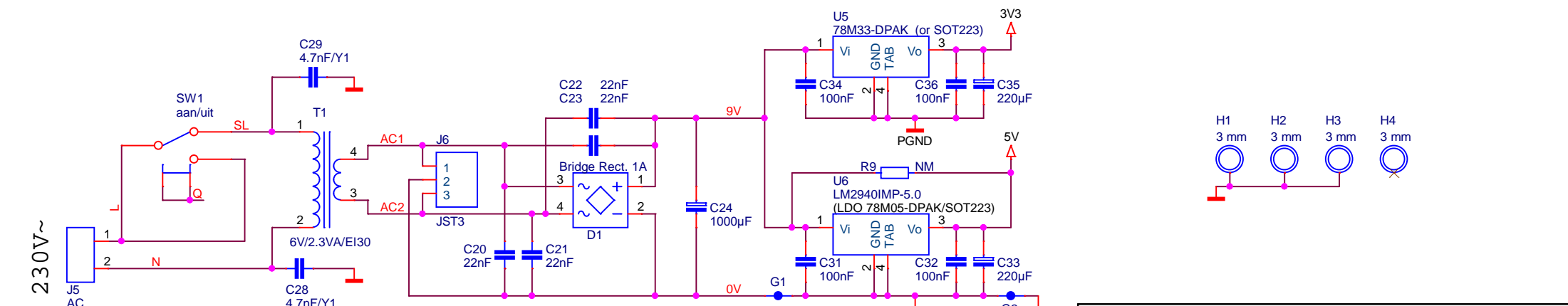
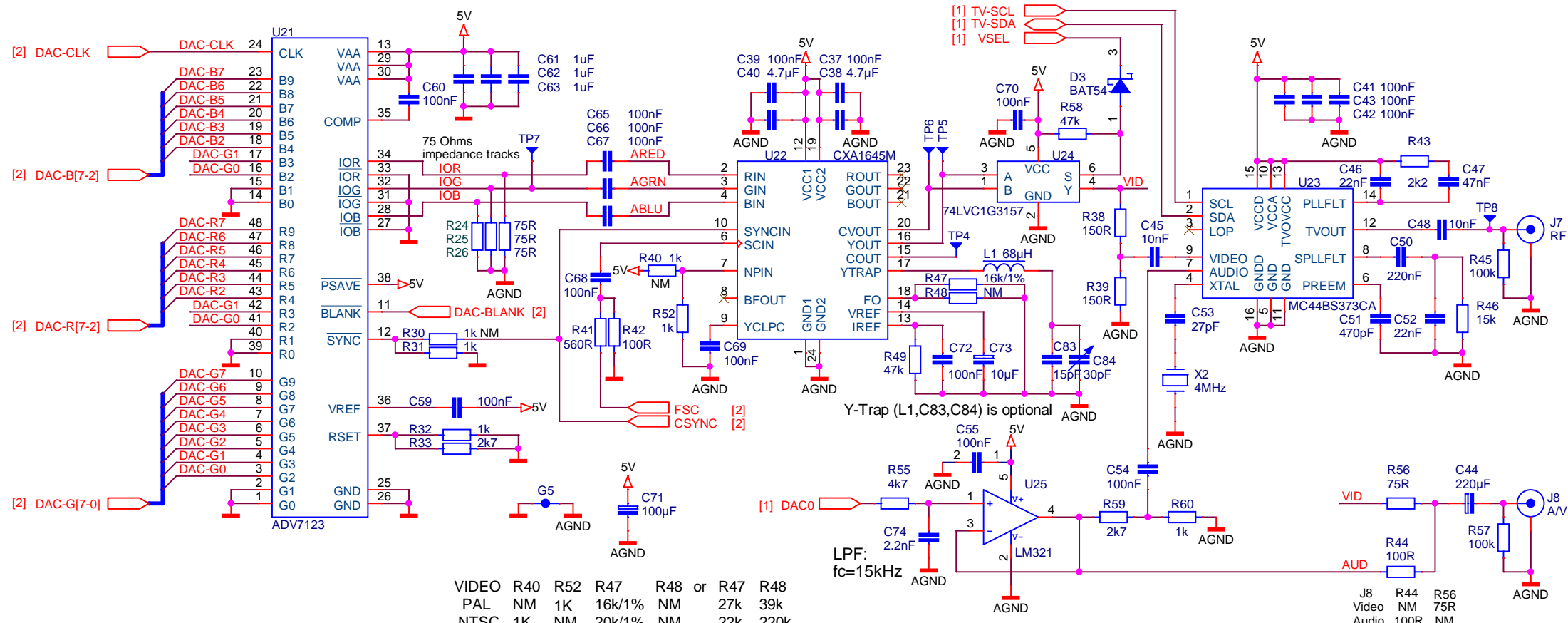

Power Supply	T1	Pin3	Pin4	C31, C32	SW1	J5	J6	C20	C21	C22	C23	D1	C31, C32	U9	R9	U5
Normal Transformer	6V/2.3VA/EI30	AC2	AC1	4.7n	SW	AC	NM	22n	22n	22n	22n	Rect.	100n	Reg	NM	78M33
Electronic Transformer	Myrra 47122	+5V	0V	4.7n	SW	AC	NM	Wire	NM	Wire	NM	NM	NM	OR	NM	LDO
DC 7..8 Volts	NM	n.a.	n.a.	NM	NM	NM	JST3	NM	NM	NM	Wire	NM	100n	Reg	NM	78M33
DC 5 Volts	NM	n.a.	n.a.	NM	NM	NM	JST3	NM	NM	Wire	NM	NM	NM	OR	NM	LDO

Title			SAM4S8B MAIN: Audio, Video, Power Supply		
Size	Document Number	TV-GENERATOR-SAM4-1-3-CXA1645.DSN			Rev
A4					1.3
Date:	Friday, February 23, 2018	Sheet	3	of	5

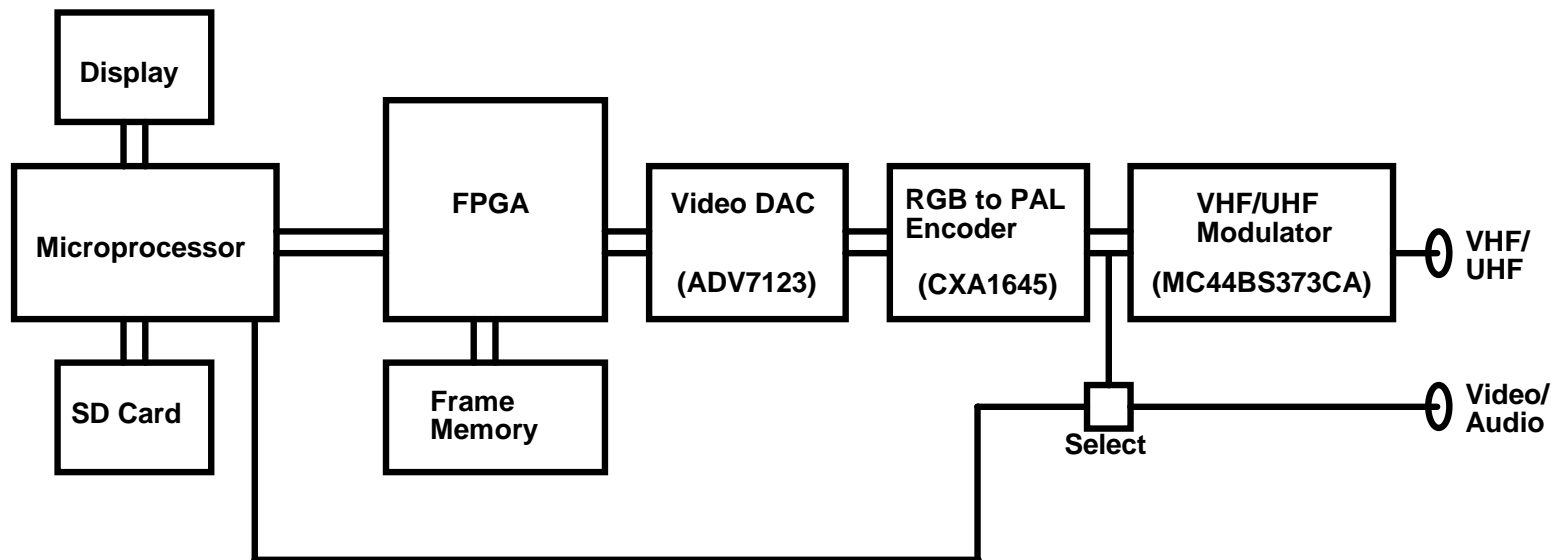

Title		
SAM4S8B MAIN: Blokschema		
Size	Document Number	Rev
A	TV-GENERATOR-SAM4-1-3-CXA1645.DSN	1.3
Date:	Tuesday, December 12, 2017	Sheet 4 of 5

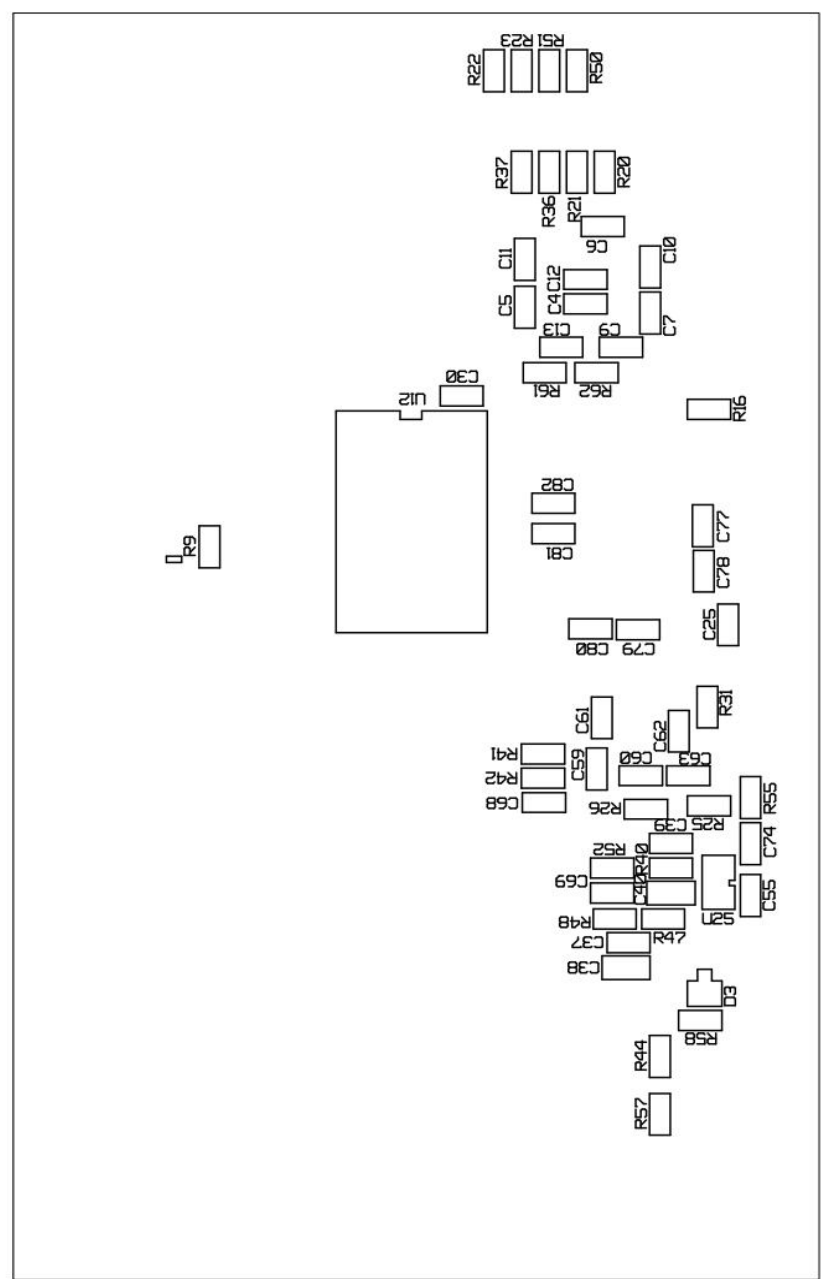
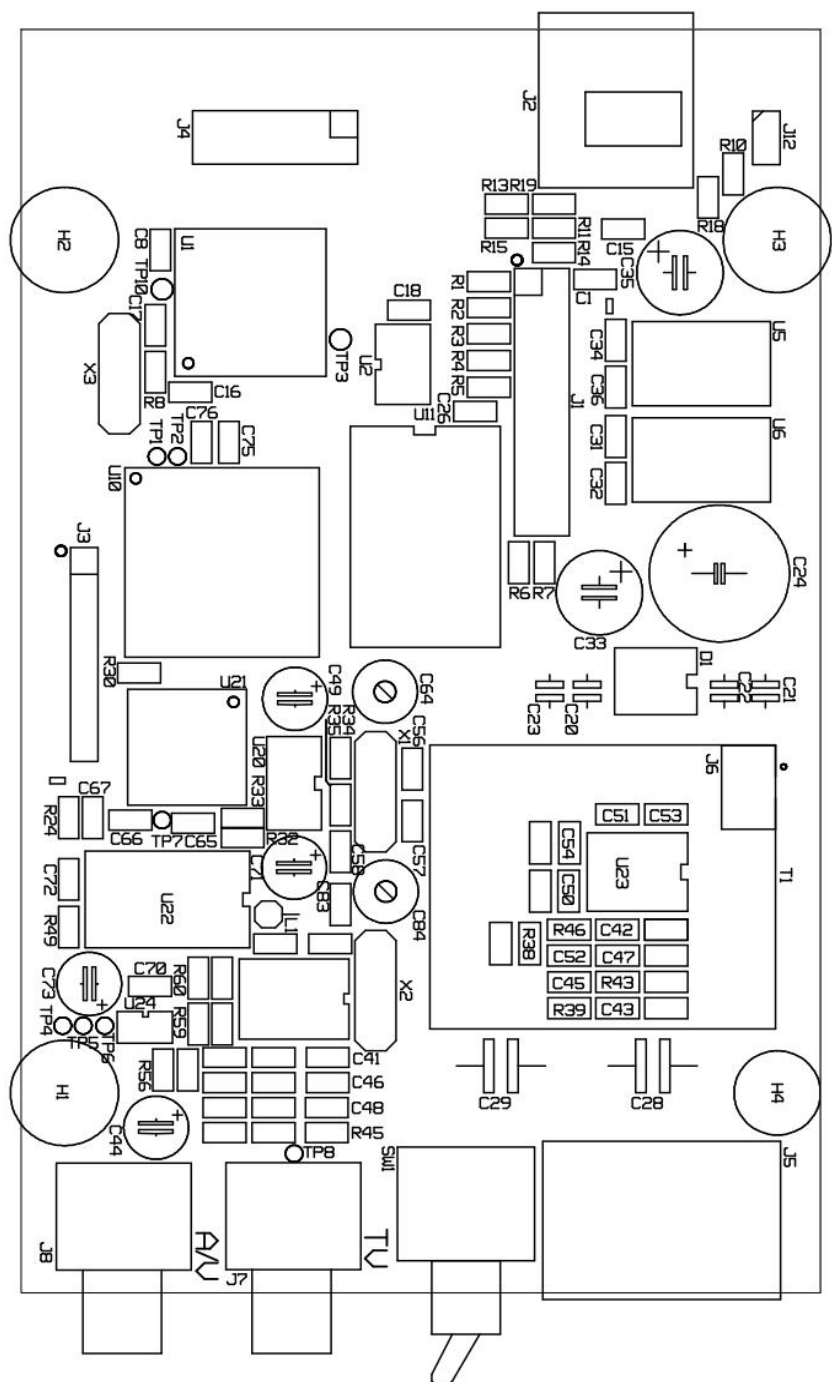

Title		
SAM4S8B MAIN: PCB		
Size	Document Number	Rev
A4	TV-GENERATOR-SAM4-1-3-CXA1645.DSN	1.3
Date:	Friday, February 23, 2018	Sheet 5 of 5